

FIRST LEGO League Challenge 2005 -- Rules

1. Read this first: To maximize performance and eliminate surprises, you must take the time to read and understand FOUR documents: The Field Setup Instructions, the Missions, the Rules, and the CURRENT Questions & Answers (Q&A) page on the web.

2. Match: At a tournament, two Challenge fields are joined back to back, and each team is paired opposite another to compete in a match. For 2-1/2 minutes, the robot tries to get the most points it can by completing missions. The timer never pauses during a match. Each match is a fresh chance for the team to get its best score, and no match has anything to do with another.

3. Mission: A mission is a job the robot can complete for points. The robot starts from Base and goes out on one or more trips to try to complete one or more missions per trip. Missions can be tried in any order, alone or in groups, re-tried when possible and allowable, or skipped. Points are given if the required results are still visible on the field at the end of the match.

4. Round: The process of cycling all teams through one match each is called a round. Most tournaments run at least 3 rounds, and teams have time between their matches to go to the pit area and work on the robot and its programs as needed.

5. Robot: The robot is defined as the RCX and anything currently connected or attached to it. Mission models and strategic objects are not part of the robot.

6. Materials: EVERYTHING the team brings with it to the COMPETITION AREA of a tournament must be made entirely of LEGO elements in original factory condition. Electrical parts are limited in type and quantity to 1 RCX, 1 rotation sensor, 2 touch sensors, 2 light sensors, 3 motors, 1 lamp, 6 AA batteries. Wires are not limited. Stickers, paint, tape, glue, oil, etc. are not allowed, except marker can be used for owner identification in hidden areas only. This rule applies only to the competition area (except remote controls are not allowed anywhere).

7. Base: Base is an imaginary hollow shape formed by vertical walls that rise from the perimeter of the Base's footprint (including the inside surfaces of the border walls), and by an invisible ceiling 16in (40cm) high. NOTE: Base is a VOLUME---not an area.

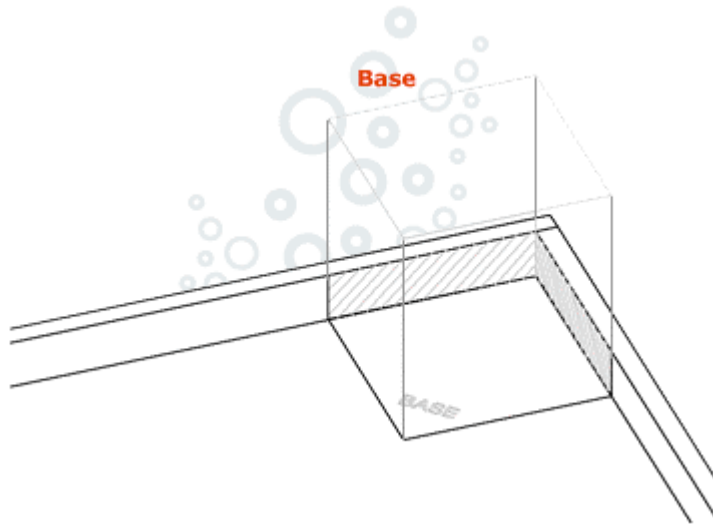

8. Autonomy: Robot performance must be autonomous (hands off). Ideally, this means that after preparation by the team, the robot is supposed to leave Base and accomplish missions BY ITSELF, and return to Base BY ITSELF if needed. Most robots require multiple trips, with some rescue and/or preparation between trips. If the team must rescue (touch/handle) the robot, depending on where the robot is and what it's doing, there can be negative consequences as described under one or more of the rules RESTARTS, BONUS LOSS, RETRIEVABLES/ROBOT TOUCHED, and LOSS OF CONTACT.

FIRST LEGO League Challenge 2005 -- Rules

9. Participation: See the Coaches' Handbook for specifics about team size and allowable ages. At the tournament, only two team members at a time are allowed right up at the competition table except during repair emergencies. The rest of the team can stay nearby, but away from the table. To share in participation, members can rotate in/out at any time.

10. Operational definitions: Though the Challenge is fun, it is robotics after all, and like all technical work it depends on specifics and exact descriptions of physical conditions. So to limit language-induced confusion, the following operational definitions are provided for the location of objects (or the robot) with respect to the missions and rules:

To/At/Reach: When an object must get TO, be AT, or REACH a target, it is sufficient for any portion of the object to barely cross over the outer edge of the destination.

On/Onto: When an object must be ON or get ONTO a target, the target should be able to support all the weight of the object when any/all other supports are removed.

In/Into: When an object must be IN or get INTO a (container-type) target, the object must be trapped from falling out or rolling away in at least 5 directions.

Touching: When and only when an object must be TOUCHING a target, the object itself must be making direct contact with the target.

Completely: When an object must meet a condition COMPLETELY, every bit of the object must meet the condition.

11. Strategic objects: Strategic objects are allowed and defined as any team-designed objects other than the robot and its attachments, used by the team or the robot, for use in or out of Base. Strategic objects with wind-up or pull-back "motors" are allowed, with these restrictions: They must be released by the robot, they must be completely out of Base when released, and the robot must be completely out of Base when it releases them.

12. Stray objects: Any object caused by a robot to be in the way of either team's robot performance can be moved by the referee (ref) upon team request unless doing so would have a direct effect on scoring, or unless the object is part of a larger mission model.

13. Preparation: Before the match and between trips into the field, the robot may be repaired, reconfigured with attachments, loaded/unloaded, and aimed. Its mechanisms may be set/reset, its buttons may be pressed, and its sensors may be signaled. This handling of the robot must take place at Base. Objects apart from the robot can be handled at Base or off the table at any time.

14. Starting position: For all starts, all portions of the robot (not just where it contacts the mat) and its currently used attachments, strategic objects, and deliverables must start from completely in Base, with leniency for slight overextensions.

15. Starting technique: To be allowed to start, the robot must be motionless and the team can not be touching it. The team is then allowed to use one of three ways to get the robot in motion: 1) Touch a button, 2) Signal a sensor, 3) Wait for a running/paused program to resume. The team must not handle the robot in any other way throughout the start. Successfully started, the robot is now performing autonomously.

16. Robot must leave base: Directly after every start, the robot must leave Base completely before it can cause any changes in the field. The robot is not allowed to cause any changes in the field while still partially in Base through extension or tethering. Also, the robot is not allowed to cause objects to leave Base unless they are being taken along in contact with it through pushing, carrying, or pulling.

FIRST LEGO League Challenge 2005 -- Rules

17. Restarts: Any time a performing robot is touched, no matter where the robot is, it is considered STOPPED and must immediately be returned to Base if it's not already there. The team may then make preparations, and follow the starting technique again when ready. NOTE: The robot does not have to return to Base unless the team touches it, or unless a mission specifically requires it.

18. Bonus objects/loss: Bonus objects are described in the missions as already being in scoring position as part of field setup. Each time the robot is touched while completely out of Base, the ref removes one bonus object from the table if there are any available at that time. If the robot is touched while in Base, or crossing into or out of Base, there is no bonus loss.

19. Housekeeping: Any objects at Base which could get in the way of the robot's preparation or motion may be kept "near" Base as long as they do not cause any changes in the field.

20. Muscle action: The team is not allowed to cause anything but the robot to leave or extend out of Base, directly or indirectly, except as described in the rules STARTING TECHNIQUE and ROBOT MUST LEAVE BASE.

21. Interference: Your team's robot is not allowed to have any effect on the other team's robot, field, or strategy except by directly meeting the scoring requirements of missions in areas that are shared between the two sides by design of the Challenge.

22. Deliverables/retrievables: Deliverables are objects which are worth points outside of Base. Retrievals are objects which are worth points at Base.

23. Deliverables/points: Points for a deliverable (unless otherwise required in a mission) are given as long as some portion of the deliverable itself is at its target, whether or not it is packaged, or joined with others.

24. Deliverables/robot touched: If the robot is touched while in contact with a deliverable, the team is given that object in Base, no matter where it came from.

25. Retrievals/points: Points for a retrievable are given as soon as the retrievable itself reaches Base, no matter where the robot is, with leniency in close situations.

26. Retrievals/robot touched: If the robot is touched while in contact with a retrievable which has not reached Base, the ref keeps that object off the field and it is not worth points, with leniency in close situations.

27. Loss of contact: When the robot is completely out of Base and loses contact with a deliverable, retrievable, or strategic object, the team can not get that object back by hand.

28. Robot damage: At any time during the match, the team can recover robot parts that come off as result of obviously unintentional damage. The team can do this by hand or request help from the ref.

29. Field damage: Except as allowed in the rules STRAY OBJECTS, HOUSEKEEPING, and DELIVERABLES/ROBOT TOUCHED, the team is not allowed to handle mission models outside of Base. The team must use the mission models supplied by the tournament and can not bring duplicates to the competition area. Changes in the field are never restored by hand for the sake of giving the team "more tries". However, if a mission model accidentally breaks, malfunctions, moves, or is activated by anything other than allowable robot action, the ref reverses the change as soon as possible, and gives the benefit of the doubt if points are in question. Intentional field damage is also reversed, but draws a warning, and may result in denial of points.

FIRST LEGO League Challenge 2005 -- Rules

30. Score determination: To minimize controversy about what happened during a Match, THE SCORE IS DETERMINED AT THE END OF THE MATCH, BY THE CONDITION OF THE FIELD AT THAT TIME ONLY. This means that points are not given for accomplishments that the robot accidentally trashes before the match ends.

31. Benefit of the doubt: In situations that are too close to call, like when a split-second or the thickness of a line is a factor, the team gets the benefit of the doubt. In general where the team disagrees with the ref and the team can respectfully raise sufficient doubt in the ref's mind, the ref meets with the head ref, and the resultant decision is final. Here, the team should NOT necessarily expect the benefit of the doubt.

32. After the match: At the end of each match, the ref and the team look at the field together and come to agreement about what points were given or missed and why, and to be sure that the team is not walking away with any mission models.

33. Precedence: When there is conflict between a mission and a rule, the mission takes precedence, but the current Q&A page on the web takes overall precedence.

34. Software: The robot must be programmed using LEGO MindStorms Robotics Invention System or RoboLab software (any version).

35. Downloading: One team's download can erase another team's programs and ruin their performance. Therefore, downloading is only allowed in the pit area, download settings must be kept on short range, the process must be shielded from surrounding teams, and the RCX should be kept OFF when not in use.

36. Challenge questions/support: For official answers to questions about the Robot Game part of the Challenge, including rulings on special strategies or situations, e-mail filtech@usfirst.org (most efficient) or call 1-800-871-8326, x118 (less efficient). For best results, be sure you've read the four documents listed above, under the rule READ THIS FIRST. When e-mailing, be sure to put "Challenge" in the subject line, and please state your role on the team (member, coach, parent, mentor). When calling, please leave your contact information slowly, your role on the team, and YOUR QUESTION on voicemail. NOTE: filtech does not answer questions about building or programming the robot. NOTE: The FLL International Forum is great for sharing ideas, but it is NOT A RELIABLE SOURCE OF ANSWERS about the Challenge.

37. Full disclosure/transparency: Since individual victory need not come at the expense of collective excellence, all official answers given to teams through Challenge support are subject to public posting in the Q&A, including answers about ALLOWABLE strategies. Also, the only documents given to the refs for reference to conduct matches and make calls are the same 4 documents you and every other team have access to all season. So if a strategy is questionable for you, chances are it will be questionable for the ref too, and guarding it until the tournament is risky.

38. Coaches' meeting: If a question does come up right before the tournament, your last chance to ask it is at the "Coaches' Meeting" the morning of the tournament. There, the head ref and the coaches meet to identify and settle any differences BEFORE the matches start. For the rest of the day, the ref's calls are final when the team leaves the table.