

# Robotics

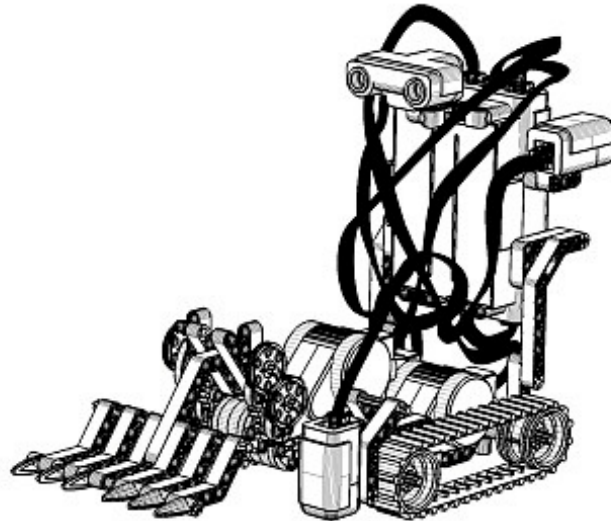

# Learning

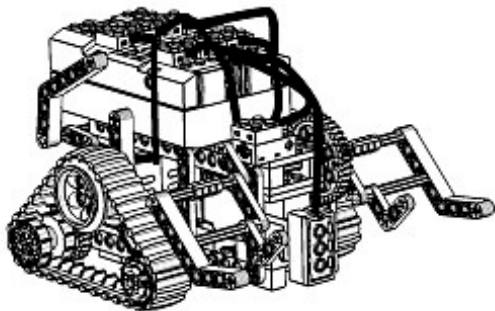

RCX and NXT Robots

Summer 2009

[www.roboticslearning.com](http://www.roboticslearning.com)

## LEGO Robotics Summer Day Camp

### 2009 Parent Handbook

*Our Vision:*

*A world where people understand technology, work productively together,  
and use technology creatively and responsibly.*

### BEGINNING LEGO RCX ROBOTICS DAY CAMP CLASS DESCRIPTION

This is a five-day fun and creative learning experience for kids to attend during the summer. Kids work in pairs to solve challenges by building and programming robots using the LEGO Mindstorms (RCX) Robotics Invention System. In addition to having fun, participants learn about mechanical and software design, problem solving, and teamwork skills. Student teams will complete several projects and mini challenges, and will have an opportunity to design and program a robot to solve FIRST LEGO League robot competition challenges from past FLL seasons (see [www.FirstLegoLeague.org](http://www.FirstLegoLeague.org)).

- **Minimum age is 8** (recommended for ages 8 – 12). No previous experience is required.
- Students will have a partner for most activities, and are expected to cooperate and share well.
- The morning part of each day includes structured lessons and activities to practice construction and programming skills.
- In the afternoon, students teams may choose from available projects or create their own projects and challenges, where they will receive guidance and coaching.
- A light snack will be provided each morning and afternoon.
- Students need to **bring their own sack lunch**, and be motivated and mature enough to stay focused on robotics activities all day.

### INTERMEDIATE LEGO NXT ROBOTICS DAY CAMP CLASS DESCRIPTION

This session is for students with previous LEGO robotics experience. Structured lessons and challenges will introduce intermediate level construction, use of sensors, and programming topics, using the LEGO NXT Mindstorms robotics kit. Student teams will have an opportunity to design and program a robot to solve FIRST LEGO League robot competition challenges from past FLL seasons (see [www.FirstLegoLeague.org](http://www.FirstLegoLeague.org)).

- **Minimum age is 9** (recommended for ages 9 – 14).
- **Previous LEGO Mindstorms experience is required** (e.g. previous class, camp, FLL, or home experience with RCX or NXT).
- Students will have a partner for most activities, and are expected to cooperate and share well.
- A light snack will be provided each morning and afternoon.
- Students need to **bring their own sack lunch**, and be motivated and mature enough to stay focused on robotics activities all day.

### PHONE NUMBERS

If you have any comments, questions or concerns, or to communicate an absence, please contact:

Phone (Steve Putz): **408-910-1176** (cell phone)  
E-Mail: **info@RoboticsLearning.com**  
Mailing Address: 586 Pomeroy Ave, Santa Clara, CA 95051

Additional Numbers (please try the above number first):  
Jewish Family and Children's Services in Palo Alto: 650-688-3030

### LOCATIONS and DATES

<b>Session 1 (Beginning): July 27-31, 2009</b> <b>Session 2 (Beginning): August 3-7, 2009</b>	<b>Session 3 (Intermediate): August 10-14, 2009</b> <b>Session 4 (Intermediate): August 17-21, 2009</b>
<b>Jewish Family and Children's Services</b> <b>200 Channing Ave.</b> <b>Palo Alto, CA 94301</b>	
<i><b>Parking:</b> Please avoid taking the last available parking spaces in the lot. Additional parking is available on the street, or the building garage (entrance on Emerson St.)</i>	

## CLASS HOURS

### All Day Sessions (9:00 AM to 4:00 PM):

Please drop off your child between 8:45 am and 9:00 am each day.  
(Supervised lunchtime is between 12:00 pm and 1:00 pm each day.)  
Please provide your child with a **sack lunch**.  
You must pick up your child **no later** than 4:15 pm each day.

## ABSENSES

Please call 408-910-1176, before 8:30 AM and leave a message if your child will be absent. Please be specific, stating your child's full name. If we do not receive a message from you, we will try to verify the absence by phone.

## SIGN-IN/SIGN-OUT POLICY

**A Parent/Guardian, or other authorized adult must sign each child in/out of camp every morning and afternoon.** The only people that your child will be released to are those listed on your information form. **Note:** all persons authorized to pick up campers must be at least 16 years of age. If someone other than a parent will pick up your child, please give us prior written notice. If there is an emergency and no one on your list can pick up your child, the primary parent/guardian must call 408-910-1176 to allow another adult to pick up the child or send a signed note of authorization with that person.

**Walking, Biking, or Taking the Bus Home:** If you plan to have your child walk, bike, or take the bus to and from camp, your child must be at least 12 years of age and you must notify Robotics Learning in writing prior to start of the camp session. Please ask for a release form for this purpose. Campers must be prompt and must sign in and out each day or they will lose this privilege.

**Late Pick-up:** After 4:15 PM, we will call the individuals you have authorized to pick up your child. After 4:30 PM, there will be a **late charge fee of \$10** for the first five minutes and **\$5** for each five-minute increment after, payable at the time of pickup. In the event we have not heard from a parent and are unable to get through to your emergency contacts, Child Protective Services will be notified. If an emergency arises, please call 408-910-1176 and leave a message that you will be late so we can explain to your child that you are on your way. Please note that repeated late pickups might result in termination from our program.

## ILLNESS/INJURY AT CAMP

If your child is ill or injured at camp, we will notify you as soon as possible so you may pick up your child. If you are not available, we will call the emergency contacts on your child's information form (please keep this information current). In an emergency, we will call emergency personnel.

**Medications:** Medication will be administered ONLY with prior written consent of parent and must be prescribed by a physician. All medications must be checked in with camp staff by a parent along with a medication consent form. Written instructions are to include medication, dosage, and conditions under which it is to be administered. All medications MUST be in their original container and have an unaltered label. Children are not allowed to bring or administer their own medication.

## REFUND/CREDIT/TRANSFER POLICY

**Refund/Credit Policy:** All deposits and payments are normally **non-refundable**. If a paid substitution from the waiting list can be made at least two weeks prior to the start of the session, you will receive a refund of **90% of your tuition**. If a substitution from the waiting list is made within two weeks of the session, you will receive a refund of 50% of your tuition. All requests for transfers, refunds or credits must be made via email or in writing.

**Transfers:** Transfers to another camp session or to another child are allowed if space is available and you give written notice (email preferred) and pay a **\$20 administration fee** at least ten days in advance of the session. If accepted, transfer requests within ten days of the session have a **\$40 administration fee**.

## WHAT TO BRING TO CAMP

**T-Shirts:** Each child will receive a Robotics Learning camp shirt on the first day of the session. We recommend that campers wear their camp shirt for easy identification and to show camp spirit.

**Bag Lunch:** For children attending the all day session, please send a bag lunch and a drink marked with your child's name each day. Please do not send perishable items (milk, mayonnaise, etc.), since refrigeration may not be available.

**Not Allowed:** A walkman, CD player, video games, Pokemon or other trading cards, skateboards or skates are not permitted at camp. They will be confiscated and returned to the parents at the end of the day.

**Valuables and Spending money:** Please leave all valuables at home (jewelry, watches, toys, etc.). Please do not bring your own LEGO sets or parts. Please label all of your child's belongings, especially coats or sweaters, with their first and last name. Camp staff will not be responsible for any valuables or money lost or stolen. To be safe, please leave all valuables and money at home.

## CAMP RULES

1. Speak for yourself... not for anyone else.
2. Listen to others... then they'll listen to you.
3. Avoid put downs... who needs them.
4. Participate in group activities and stay with the group.
5. Show respect... every person is important.
6. Take charge of yourself... you are responsible for you!
7. Have fun!

**www.RoboticsLearning.com**  
**586 Pomeroy Ave, Santa Clara, CA 95051**  
**408-910-1176**

# Robotics



# Learning

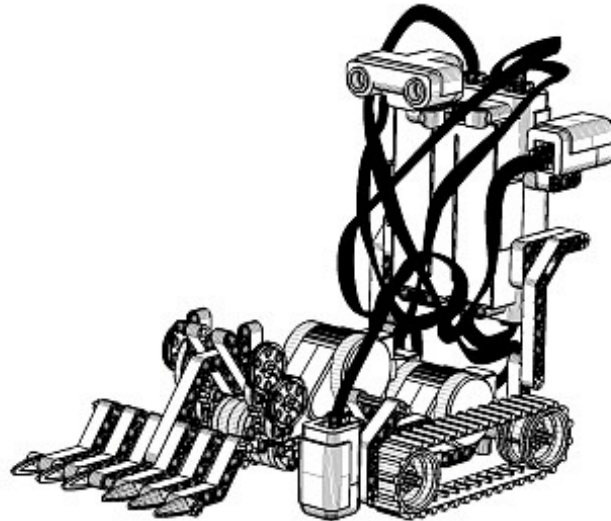
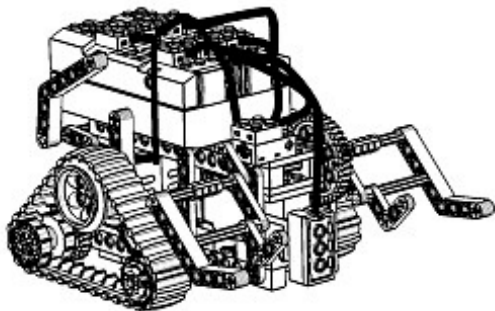

RCX and NXT Robots

Summer 2009

[www.roboticslearning.com](http://www.roboticslearning.com)

## LEGO Robotics Summer Day Camp

### 2009 Parent Handbook

*Our Vision:*

*A world where people understand technology, work productively together,  
and use technology creatively and responsibly.*

### BEGINNING LEGO RCX ROBOTICS DAY CAMP CLASS DESCRIPTION

This is a five-day fun and creative learning experience for kids to attend during the summer. Kids work in pairs to solve challenges by building and programming robots using the LEGO Mindstorms (RCX) Robotics Invention System. In addition to having fun, participants learn about mechanical and software design, problem solving, and teamwork skills. Student teams will complete several projects and mini challenges, and will have an opportunity to design and program a robot to solve FIRST LEGO League robot competition challenges from past FLL seasons (see [www.FirstLegoLeague.org](http://www.FirstLegoLeague.org)).

- **Minimum age is 8** (recommended for ages 8 – 12). No previous experience is required.
- Students will have a partner for most activities, and are expected to cooperate and share well.
- The morning part of each day includes structured lessons and activities to practice construction and programming skills.
- In the afternoon, students teams may choose from available projects or create their own projects and challenges, where they will receive guidance and coaching.
- A light snack will be provided each morning and afternoon.
- Students need to **bring their own sack lunch**, and be motivated and mature enough to stay focused on robotics activities all day.

### INTERMEDIATE LEGO NXT ROBOTICS DAY CAMP CLASS DESCRIPTION

This session is for students with previous LEGO robotics experience. Structured lessons and challenges will introduce intermediate level construction, use of sensors, and programming topics, using the LEGO NXT Mindstorms robotics kit. Student teams will have an opportunity to design and program a robot to solve FIRST LEGO League robot competition challenges from past FLL seasons (see [www.FirstLegoLeague.org](http://www.FirstLegoLeague.org)).

- **Minimum age is 9** (recommended for ages 9 – 14).
- **Previous LEGO Mindstorms experience is required** (e.g. previous class, camp, FLL, or home experience with RCX or NXT).
- Students will have a partner for most activities, and are expected to cooperate and share well.
- A light snack will be provided each morning and afternoon.
- Students need to **bring their own sack lunch**, and be motivated and mature enough to stay focused on robotics activities all day.

### PHONE NUMBERS

If you have any comments, questions or concerns, or to communicate an absence, please contact:

Phone (Steve Putz): **408-910-1176** (cell phone)  
E-Mail: **info@RoboticsLearning.com**  
Mailing Address: 586 Pomeroy Ave, Santa Clara, CA 95051

Additional Numbers (please try the above number first):  
Jewish Family and Children's Services in Palo Alto: 650-688-3030

### LOCATIONS and DATES

<b>Session 1 (Beginning): July 27-31, 2009</b> <b>Session 2 (Beginning): August 3-7, 2009</b>	<b>Session 3 (Intermediate): August 10-14, 2009</b> <b>Session 4 (Intermediate): August 17-21, 2009</b>
<b>Jewish Family and Children's Services</b> <b>200 Channing Ave.</b> <b>Palo Alto, CA 94301</b>	
<i><b>Parking:</b> Please avoid taking the last available parking spaces in the lot. Additional parking is available on the street, or the building garage (entrance on Emerson St.)</i>	

## CLASS HOURS

### All Day Sessions (9:00 AM to 4:00 PM):

Please drop off your child between 8:45 am and 9:00 am each day.  
(Supervised lunchtime is between 12:00 pm and 1:00 pm each day.)  
Please provide your child with a **sack lunch**.  
You must pick up your child **no later** than 4:15 pm each day.

## ABSENCES

Please call 408-910-1176, before 8:30 AM and leave a message if your child will be absent. Please be specific, stating your child's full name. If we do not receive a message from you, we will try to verify the absence by phone.

## SIGN-IN/SIGN-OUT POLICY

**A Parent/Guardian, or other authorized adult must sign each child in/out of camp every morning and afternoon.** The only people that your child will be released to are those listed on your information form. **Note:** all persons authorized to pick up campers must be at least 16 years of age. If someone other than a parent will pick up your child, please give us prior written notice. If there is an emergency and no one on your list can pick up your child, the primary parent/guardian must call 408-910-1176 to allow another adult to pick up the child or send a signed note of authorization with that person.

**Walking, Biking, or Taking the Bus Home:** If you plan to have your child walk, bike, or take the bus to and from camp, your child must be at least 12 years of age and you must notify Robotics Learning in writing prior to start of the camp session. Please ask for a release form for this purpose. Campers must be prompt and must sign in and out each day or they will lose this privilege.

**Late Pick-up:** After 4:15 PM, we will call the individuals you have authorized to pick up your child. After 4:30 PM, there will be a **late charge fee of \$10** for the first five minutes and **\$5** for each five-minute increment after, payable at the time of pickup. In the event we have not heard from a parent and are unable to get through to your emergency contacts, Child Protective Services will be notified. If an emergency arises, please call 408-910-1176 and leave a message that you will be late so we can explain to your child that you are on your way. Please note that repeated late pickups might result in termination from our program.

## ILLNESS/INJURY AT CAMP

If your child is ill or injured at camp, we will notify you as soon as possible so you may pick up your child. If you are not available, we will call the emergency contacts on your child's information form (please keep this information current). In an emergency, we will call emergency personnel.

**Medications:** Medication will be administered ONLY with prior written consent of parent and must be prescribed by a physician. All medications must be checked in with camp staff by a parent along with a medication consent form. Written instructions are to include medication, dosage, and conditions under which it is to be administered. All medications MUST be in their original container and have an unaltered label. Children are not allowed to bring or administer their own medication.

## REFUND/CREDIT/TRANSFER POLICY

**Refund/Credit Policy:** All deposits and payments are normally **non-refundable**. If a paid substitution from the waiting list can be made at least two weeks prior to the start of the session, you will receive a refund of **90% of your tuition**. If a substitution from the waiting list is made within two weeks of the session, you will receive a refund of 50% of your tuition. All requests for transfers, refunds or credits must be made via email or in writing.

**Transfers:** Transfers to another camp session or to another child are allowed if space is available and you give written notice (email preferred) and pay a **\$20 administration fee** at least ten days in advance of the session. If accepted, transfer requests within ten days of the session have a **\$40 administration fee**.

## WHAT TO BRING TO CAMP

**T-Shirts:** Each child will receive a Robotics Learning camp shirt on the first day of the session. We recommend that campers wear their camp shirt for easy identification and to show camp spirit.

**Bag Lunch:** For children attending the all day session, please send a bag lunch and a drink marked with your child's name each day. Please do not send perishable items (milk, mayonnaise, etc.), since refrigeration may not be available.

**Not Allowed:** A walkman, CD player, video games, Pokemon or other trading cards, skateboards or skates are not permitted at camp. They will be confiscated and returned to the parents at the end of the day.

**Valuables and Spending money:** Please leave all valuables at home (jewelry, watches, toys, etc.). Please do not bring your own LEGO sets or parts. Please label all of your child's belongings, especially coats or sweaters, with their first and last name. Camp staff will not be responsible for any valuables or money lost or stolen. To be safe, please leave all valuables and money at home.

## CAMP RULES

1. Speak for yourself... not for anyone else.
2. Listen to others... then they'll listen to you.
3. Avoid put downs... who needs them.
4. Participate in group activities and stay with the group.
5. Show respect... every person is important.
6. Take charge of yourself... you are responsible for you!
7. Have fun!

**www.RoboticsLearning.com**  
**586 Pomeroy Ave, Santa Clara, CA 95051**  
**408-910-1176**